

Ego easy

THREADED/FLANGED CIRCULATORS

Ego (T) (C) easy -60, -80, -100, -120 single and twin



High performance wet rotor circulation pump with threaded or flanged connection, motor with permanent magnets and built-in electronic controller.

APPLICATION

Residential and industrial heating and air-conditioning systems.

FEATURES

- Built-in frequency converter
- Multiple operating modes
- Numeric and graphical display for easy setup and visualisation of parameters
- Automatic venting function
- Built-in overload safety device
- High input torque (with consequent automatic release of the rotor)
- Optional communication module (with Ethernet port, 0-10V contact, digital inputs etc.)

PUMP TECHNICAL DATA

- Liquid temperature: $-10 \div +110 \text{ }^\circ\text{C}$
- Room temperature: $0 \div +40 \text{ }^\circ\text{C}$
- Relative air humidity: $\leq 95\%$
- Allowed fluids: clean, not aggressive and not flammable, free of solid particles or fibres
- Maximum pressure: 10 bar
- Minimum suction pressure:
 - 0,05 bar a $50 \text{ }^\circ\text{C}$
 - 0,8 bar a $80 \text{ }^\circ\text{C}$
 - 1,4 bar a $110 \text{ }^\circ\text{C}$
- Maximum amount of glycol: 20%*
- Threaded inlets: G1½" – 2" (in accordance with ISO 228)
- Flanged inlets: from DN 32 to DN 50
- Protection degree: IP44

MOTOR TECHNICAL DATA

- Type: synchronous with permanent magnets
- Motor speed: variable
- Supply voltage: 1~230V
- Frequency: 50/60 Hz
- Insulation class: F

* For greater amounts please check the final viscosity and the conditions of use

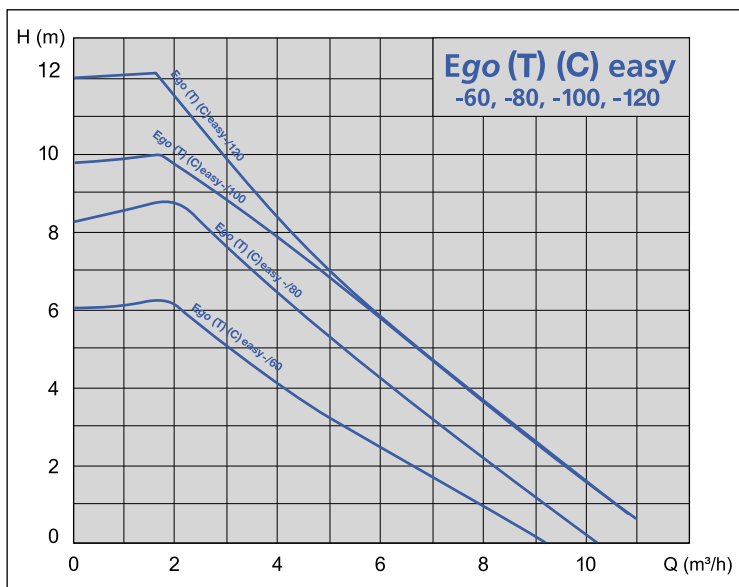

IDENTIFICATION CODE

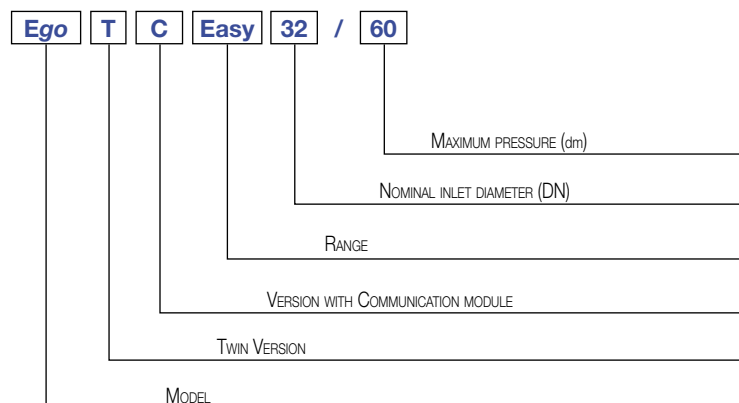

THREADED/FLANGED CIRCULATORS

Ego (T) (C) easy -60, -80, -100, -120 single and twin

OPERATING MODES

The operating modes can be selected using the buttons located on the rear panel:

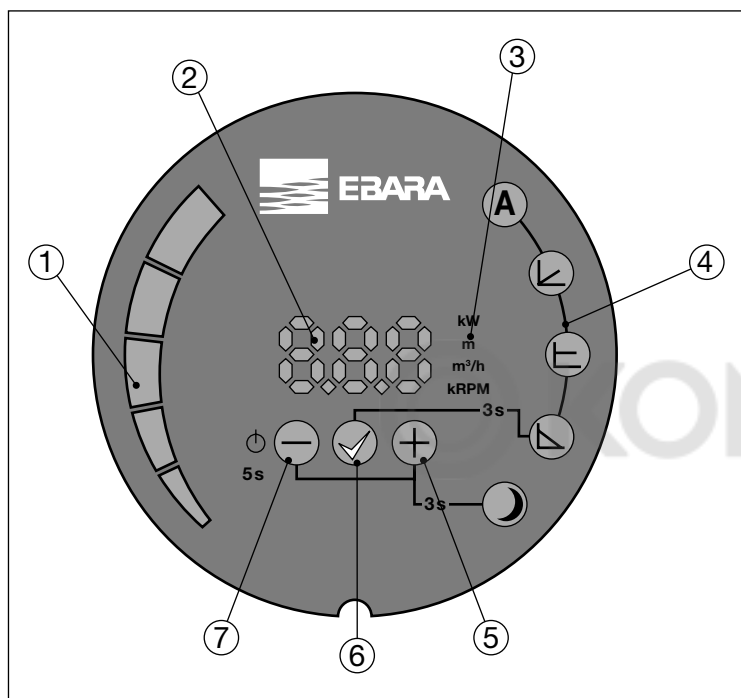

KEY

- 1 Segment display
- 2 Numeric display
- 3 Display of selected parameter
- 4 Display of selected mode
- 5 Selection key
- 6 Confirmation key
- 7 Selection key

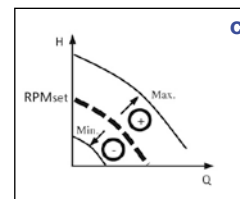
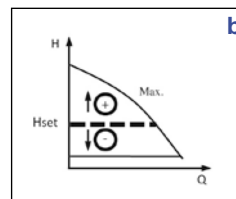
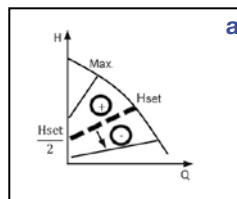

A AUTO mode (factory setting)
The circulator automatically adjusts the hydraulic performance depending on the actual requirements of the system, continuously measuring the optimal H/Q point. This operating mode is suitable for most applications and ensures high energy savings.

Proportional pressure ($\Delta P-v$) - fig. a
The circulator adjusts the pump head depending on the flow rate, varying the latter linearly from a maximum value (H_{set}) to a minimum value (equal to $H_{set}/2$). The pressure value (H_{set}) is set via buttons \oplus and \ominus and is expressed in metres; the minimum value is automatically calculated by the circulator.

Constant pressure ($\Delta P-c$) - fig. b
The circulator maintains the pump head constant when the flow rates varies. The value of the pressure (H_{set}) is set via buttons \oplus and \ominus and is expressed in metres.

Constant speed - fig. c
The circulator operates according to a constant curve set via buttons \oplus and \ominus (by selecting the rotation speed in "rpm").

Night mode
Night mode can be activated in combination with any of the operating modes listed above, and allows the circulator to operate at a minimum curve (therefore with very low consumption) when it detects a decrease in liquid temperature of 15-20 ° C. When temperature rises, it automatically returns to normal operating curve (according to the selected mode).

Ego easy

THREADED/FLANGED CIRCULATORS

Ego (T) (C) easy -60, -80, -100, -120 single and twin

COMMUNICATION MODULE

Versions **Ego T C easy** are equipped with an additional communication module which can be accessed by opening the rear display panel. The communication module is also available as an optional accessory. It is compatible with all standard models Ego easy. The module enables running a wide range of applications remotely:

- Access via Ethernet
- Remote On/Off
- Analog control 0-10V
- Modbus RTU
- Alarm/state relay

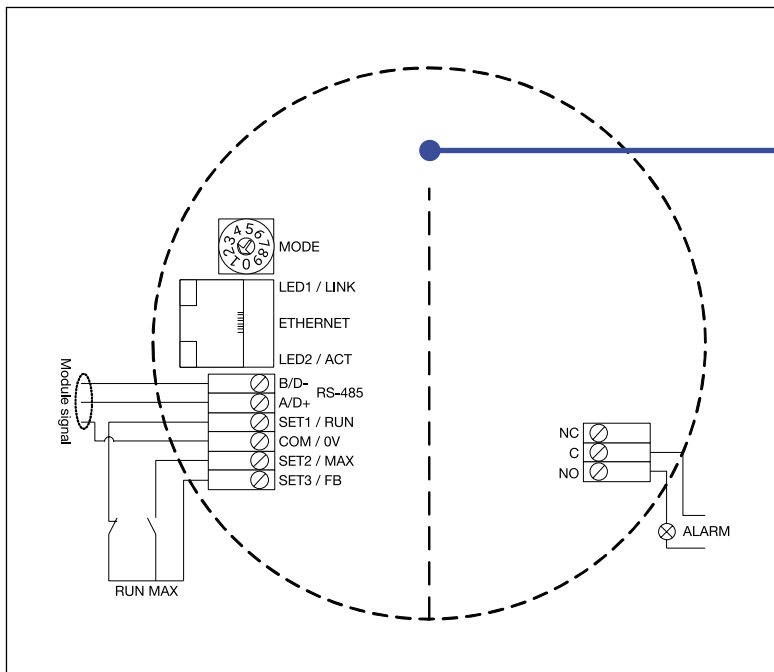
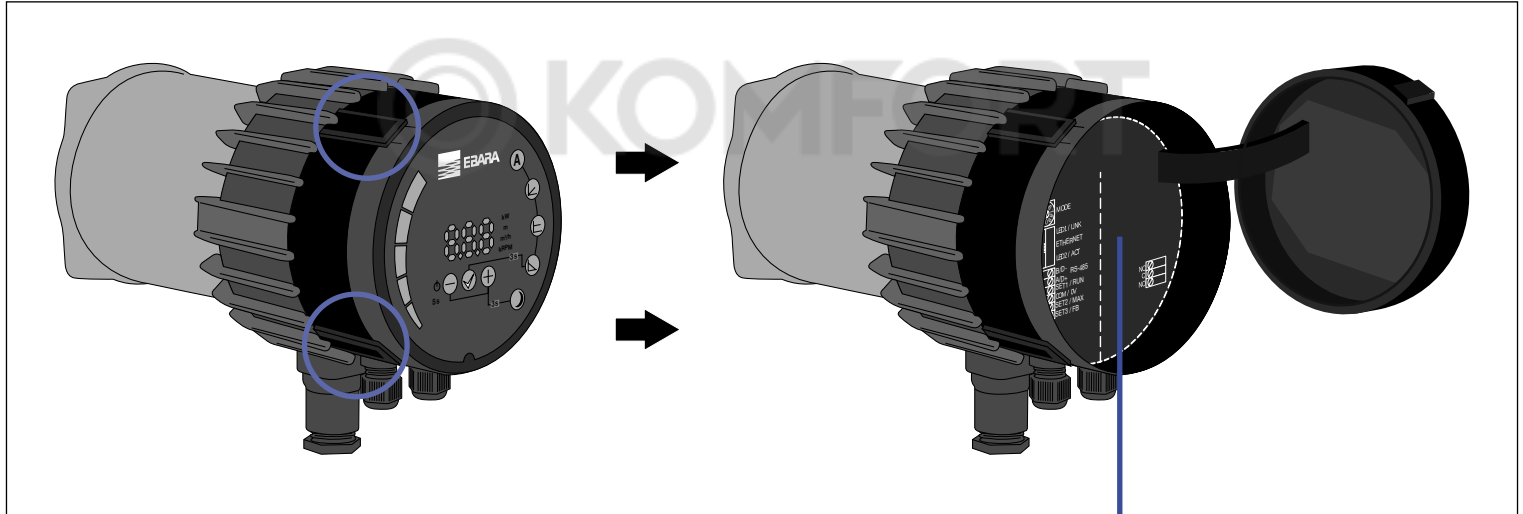

Ego easy

THREADED/FLANGED CIRCULATORS

Ego (T) (C) easy -60, -80, -100, -120 single and twin

PERFORMANCE CURVES

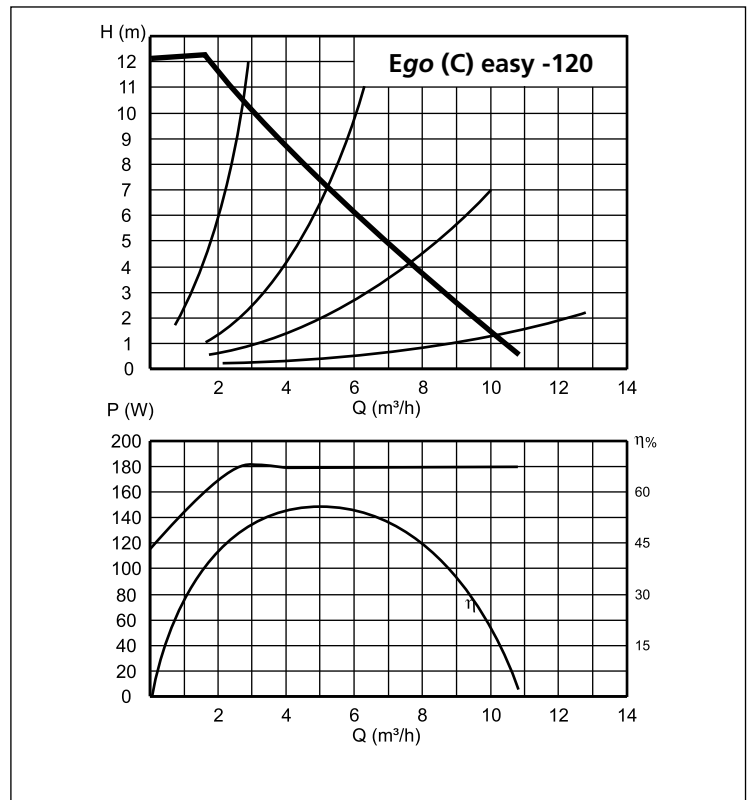
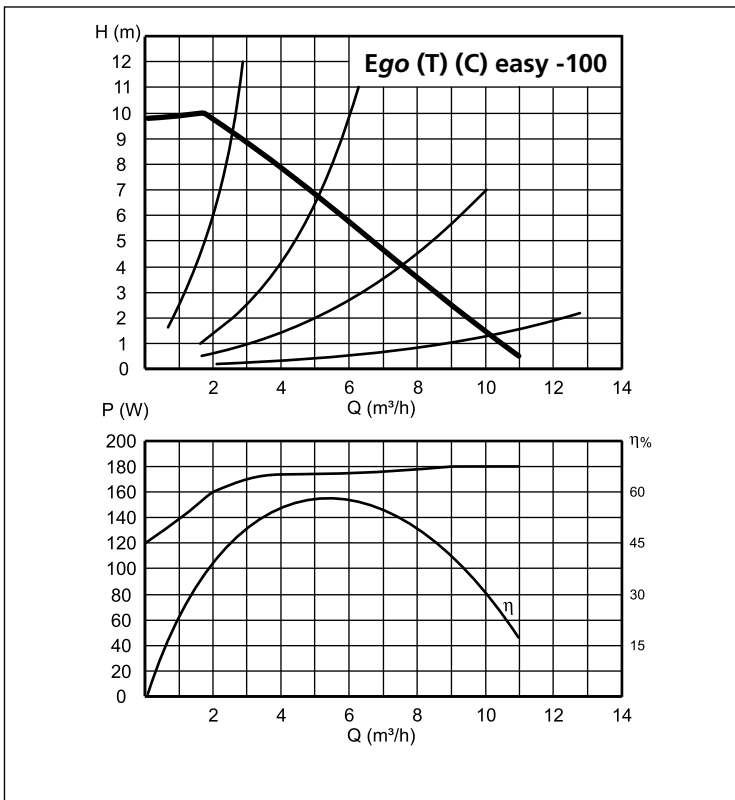
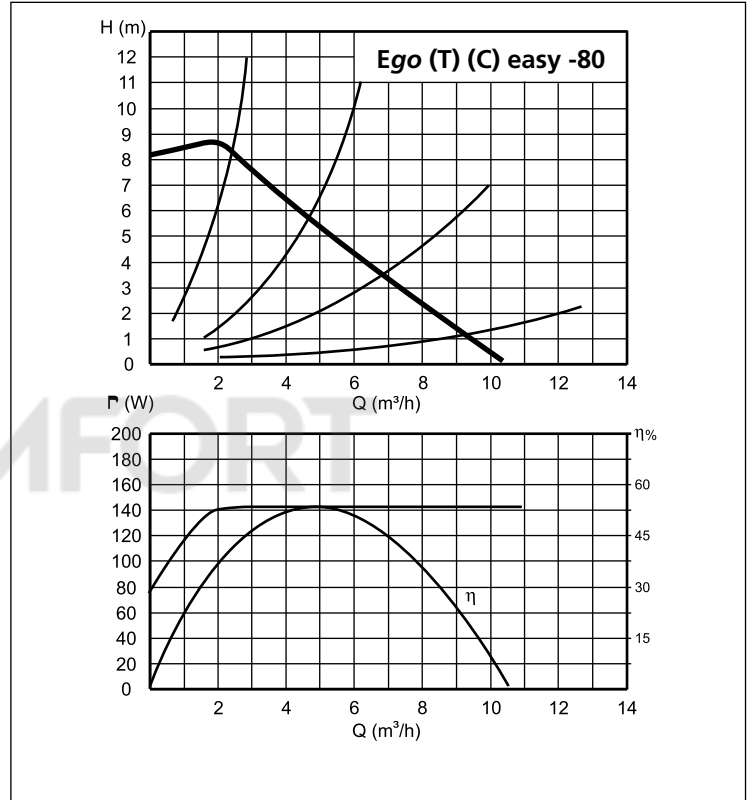
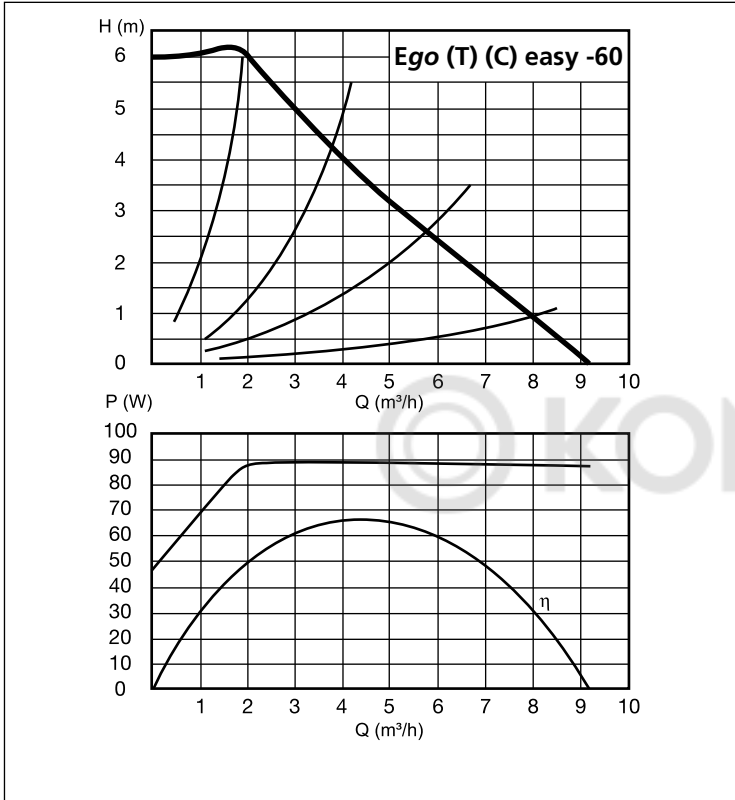

The content of this publication should not be considered mandatory. EBARA Pumps Europe S.p.A. reserves the right to change the content without prior notice.

Ego easy

THREADED/FLANGED CIRCULATORS

Ego (T) (C) easy -60, -80, -100, -120 single and twin

SECTIONAL VIEW

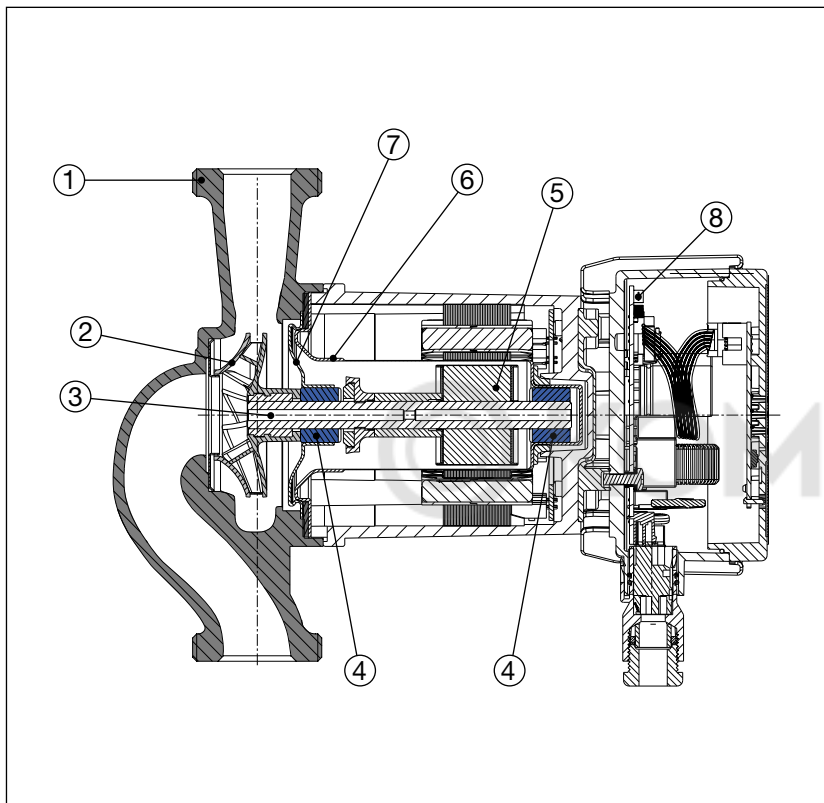

TABLE OF MATERIALS

Ref.	Part	Material
1	Pump body	Cast iron with cataphoresis coating
2	Impeller	Technopolymer
3	Shaft	Stainless steel
4	Bearings	Graphite
5	Rotor	Coated in stainless steel
6	Rotor can	AISI 316 Stainless Steel
7	Bearing plate	AISI 316 Stainless Steel
8	Electronic board	-

TECHNICAL FEATURES - single

Model	EEl (energy efficiency index)	Pipe connection	Inlet fitting	Power P ₁ [W] P _{max}	Current consumption [A] I _{min} - I _{max}	Weight [kg]
Ego easy 25-60	≤ 0,21	G1 1/2"	Rp 1"	90	0,1 ÷ 0,75	4,0
Ego easy 32-60	≤ 0,21	G2"	Rp 1 1/4"	90	0,1 ÷ 0,75	4,1
Ego easy 25-80	≤ 0,21	G1 1/2"	Rp 1"	140	0,1 ÷ 1,15	4,0
Ego easy 32-80	≤ 0,21	G2"	Rp 1 1/4"	140	0,1 ÷ 1,15	4,1
Ego easy 25-100	≤ 0,21	G1 1/2"	Rp 1"	180	0,1 ÷ 1,5	4,0
Ego easy 32-100	≤ 0,21	G2"	Rp 1 1/4"	180	0,1 ÷ 1,5	4,1
Ego easy 25-120	≤ 0,22	G1 1/2"	Rp 1 1/2"	180	0,1 ÷ 1,5	4,0
Ego easy 32-120	≤ 0,22	G2"	Rp 2"	180	0,1 ÷ 1,5	4,1
Ego easy 40-60F	≤ 0,21	DN 40	-	180	0,1 ÷ 0,75	8,7
Ego easy 32-100F	≤ 0,21	DN 32	-	180	0,1 ÷ 1,5	7,4
Ego easy 40-100F	≤ 0,21	DN 40	-	180	0,1 ÷ 1,5	8,5
Ego easy 50-100F	≤ 0,21	DN 50	-	180	0,1 ÷ 1,5	9,8

TECHNICAL FEATURES - twin

Model	EEl (energy efficiency index)	Pipe connection	Inlet fitting	Power P ₁ [W] P _{max}	Current consumption [A] I _{min} - I _{max}	Weight [kg]
Ego T C easy 32-60	≤ 0,21	G2"	Rp 1 1/4"	90	0,1 ÷ 0,75	8,2
Ego T C easy 32-80	≤ 0,21	G2"	Rp 1 1/4"	140	0,1 ÷ 1,15	8,2
Ego T C easy 32-100	≤ 0,21	G2"	Rp 1 1/4"	180	0,1 ÷ 1,50	8,2
Ego T C easy 40-100F	≤ 0,21	DN 40	-	180	0,1 ÷ 1,50	11,0

THREADED/FLANGED CIRCULATORS

Ego (T) (C) easy -60, -80, -100, -120 single and twin

DIMENSIONS - single

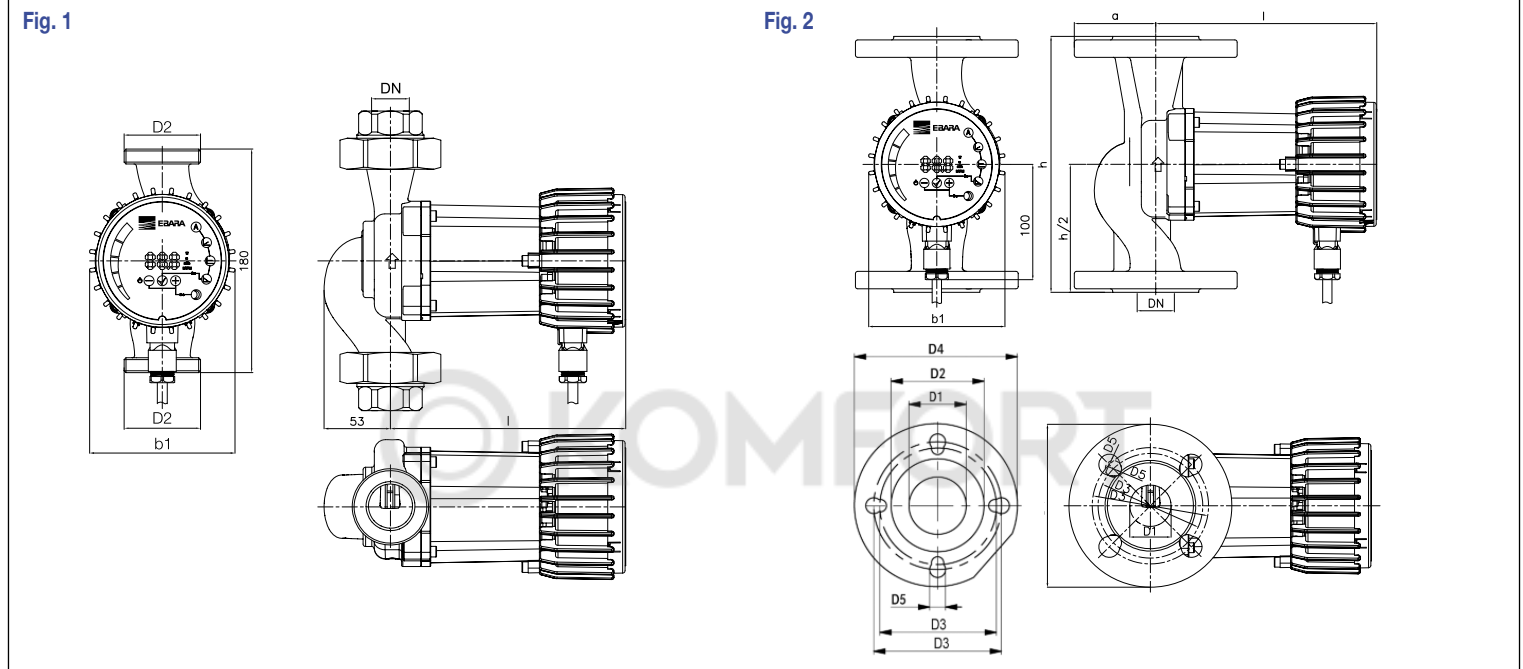

TABLE OF DIMENSIONS - single

Ref.	Model	Dimensions [mm]										
		h	DN	b1	l	a	D1	D2	D3	D4	D5	n. of holes
Fig. 1	Ego easy 25-60	180	25	117	190 (222)*	-	-	1 1/2"	-	-	-	-
	Ego easy 32-60	180	32	117	190 (222)*	-	-	2"	-	-	-	-
	Ego easy 25-80	180	25	117	190 (222)*	-	-	1 1/2"	-	-	-	-
	Ego easy 32-80	180	32	117	190 (222)*	-	-	2"	-	-	-	-
	Ego easy 25-100	180	25	117	190 (222)*	-	-	1 1/2"	-	-	-	-
	Ego easy 32-100	180	32	117	190 (222)*	-	-	2"	-	-	-	-
	Ego easy 25-120	180	25	117	190 (222)*	-	-	1 1/2"	-	-	-	-
Fig. 2	Ego easy 32-120	180	32	117	190 (222)*	-	-	2"	-	-	-	-
	Ego easy 40-60F	220	40	117	190 (222)*	75	40	80	100/110	150	14/19	4
	Ego easy 32-100F	220	32	117	190 (222)*	70	32	74	90/100	140	14/18	4
	Ego easy 40-100F	220	40	117	190 (222)*	75	40	80	100/110	150	14/19	4
	Ego easy 50-100F	240	50	117	190 (222)*	82,5	50	90	110/125	165	14/19	4

* Dimensions in bracket are referred to Ego easy with communication module

The content of this publication should not be considered mandatory. EBARA Pumps Europe S.p.A. reserves the right to change the content without prior notice.

THREADED/FLANGED CIRCULATORS

Ego (T) (C) easy -60, -80, -100, -120 single and twin

DIMENSIONS - twin

Fig. 1

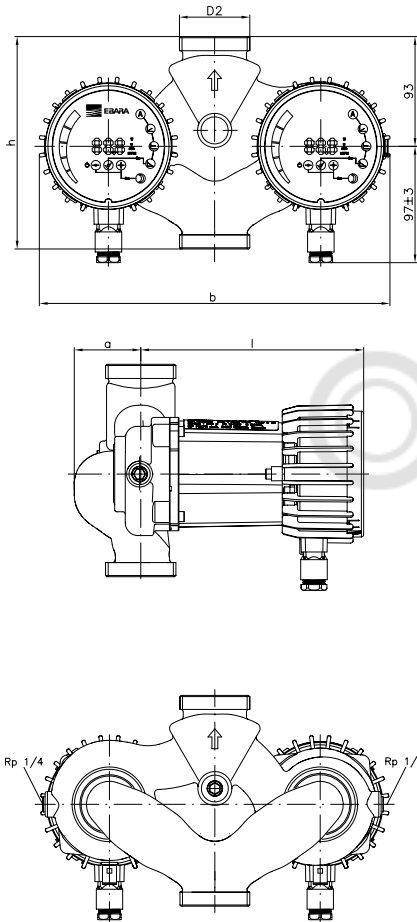
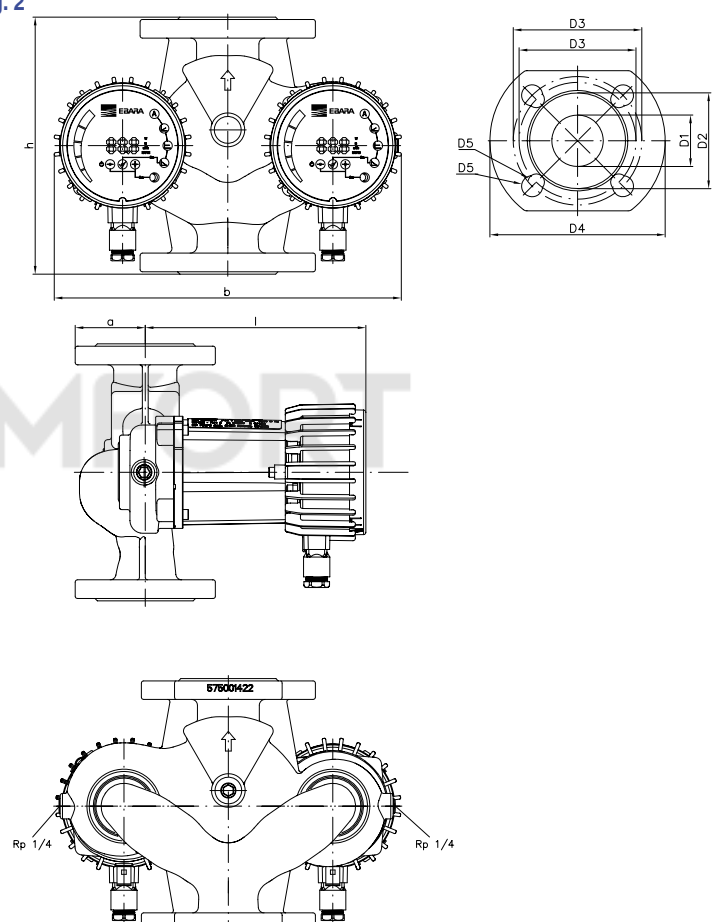

Fig. 2



DIMENSIONS - twin

Ref.	Model	Dimensions [mm]										
		h	DN	b	l	a	D1	D2	D3	D4	D5	n. of holes
Fig. 1	Ego T C easy 32-60	180	32	297	222	56	-	2"	-	-	-	-
	Ego T C easy 32-80	180	32	297	222	56	-	2"	-	-	-	-
	Ego T C easy 32-100	180	32	297	222	56	-	2"	-	-	-	-
Fig. 2	Ego T C easy 40-100F	220	40	297	222	75	40	80	100/110	150	14/19	4

Communication module is standard for twin version

Ego easy

THREADED/FLANGED CIRCULATORS

Ego (T) (C) easy -60, -80, -100, -120 single and twin

ASSEMBLY POSITION

