

de Stabtemperaturfühler
 fr Sonde de température de gaine
 en Duct temperature sensor
 it Sonda di temperatura ad asta
 es Sonda temperatura de caña
 sv Stavtemperaturgivare
 nl Staaftemperatuur opnemer

de Montagevorschrift
 fr Instruction de montage
 en Fitting instructions
 it Istruzioni di montaggio
 es Instrucciones de montaje
 sv Monteringanvisning
 nl Montagevoorschrift

EGT 346...348
 EGT 346...348F031
 EGT 392
 EGT 446, 447
 EGT 646, 647

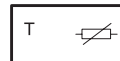

de Installationsanweisung für die Elektrofachkraft
 fr Notice d'installation pour l'électricien
 en Guidelines for the electrician
 it Informazioni per l'installatore elettrico
 es Instrucciones de instalación para el electricista
 sv Installationsinstruktion för behörig elektriker
 nl Installatie aanwijzing voor de elektromonteur

de Für den Einsatz in üblicher Umgebung
 fr Pour usage dans un environnement normal
 en For use in normal environments
 it Per impiego in ambiente usuale
 es Para el uso en ambiente normal
 sv För användning i normal miljö

EGT 346...348
 EGT 346...348F031
 EGT 446, 447
 EGT 646, 647

nl Voor toepassing in normale omgeving

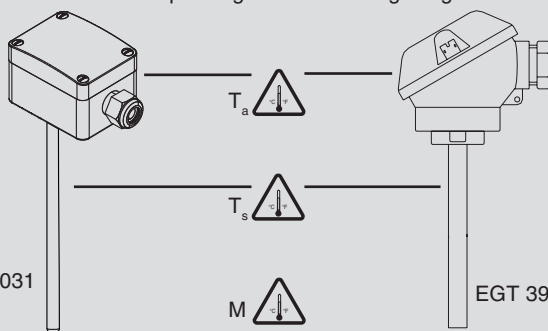

de Messbereich
 fr Mesure
 en Measured value
 it Valore misurato
 es Valor de medición
 sv Mätvärde
 nl Meetwaarde

de Gerätekopftemperatur
 fr Température à la tête de l'appareil
 en Temperature of instrumenthead
 it Temperatura alla testa dell'apparato
 es Temperatura del cabezal del dispositivo
 sv Temperatur givarhuvud
 nl Temperatuur apparaatkop

de Oberflächentemperatur des Fühlers
 fr Température de surface de la sonde
 en Surface temperature of the sensor
 it Temperatura superficiale della sonda
 es Temperatura superficial de la sonda
 sv Givarens ytemperatur
 nl Oppervlaktetemperatuur van de sensor



EGT 346...348, 446, 447, 646, 647	-50...160 °C	-35...90°C	-35...90°C
EGT 346...348F031	-50...160 °C	-35...70°C	-35...70°C
EGT 392	-50...260 °C	-25...90°C	-25...90°C



[mm]

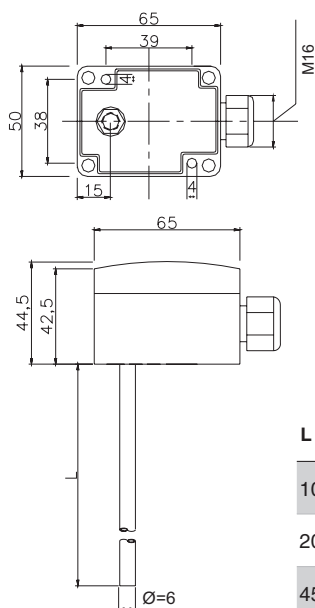

L	Typ
100 mm	EGT 346, EGT 446, EGT 646
200 mm	EGT 347, EGT 447, EGT 647
450 mm	EGT 348



EGT 392

[mm]

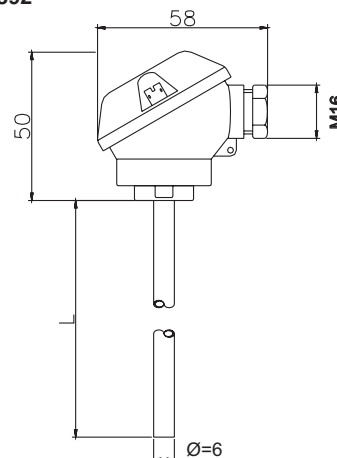

L	Typ
100mm	EGT 392

1a

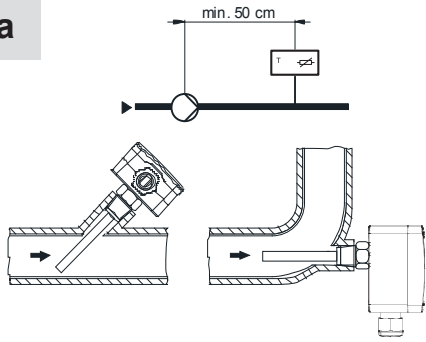

1b



max. 150° C

de Wärmeleitpaste 0300360004
 fr Pâte conductrice 0300360004
 en Thermal conducting paste 0300360004
 it Pasta termococonduttiva 0300360004
 es Pasta conductora de calor 0300360004
 sv Värmeledande pasta 0300360004
 nl Warmtegeleidingspasta 0300360004



2

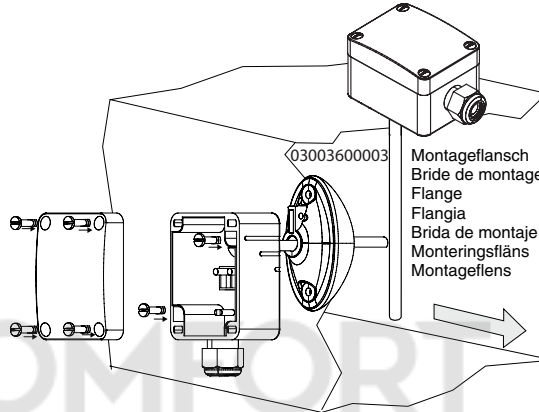
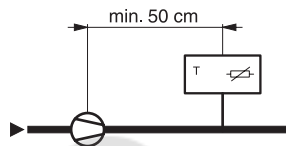

max. 140° C

3a

EGT 346F022, F102
 EGT 347F102
 EGT 348F102
 EGT 446, 447
 EGT 464, 647

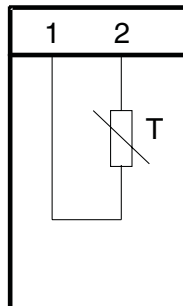

EGT 392

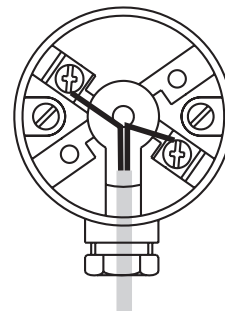

3b

EGT 346F031
 EGT 347F031
 EGT 348F031

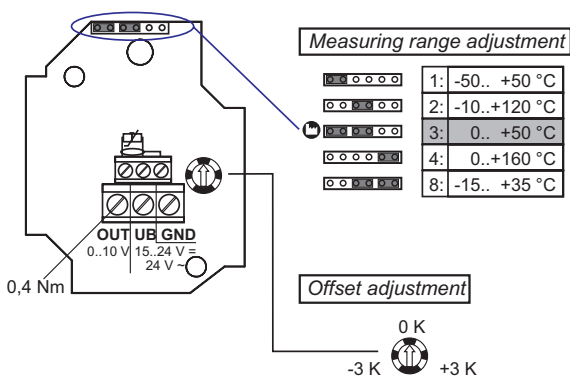

3c

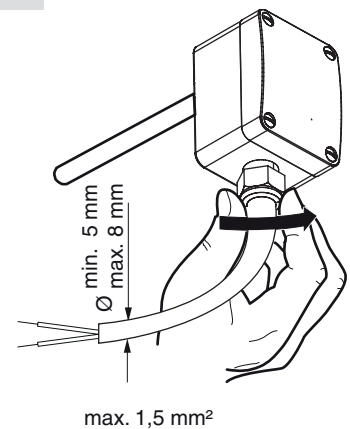

de Dokument aufbewahren
 fr Ce document est à conserver
 en Retain this document
 it Conservare il documento
 es Guardar el documento
 sv Spara dokumentationen
 nl Document bewaren

© SAUTER Head Office
 Fr. Sauter AG
 Im Surinam 55
 CH-4058 Basel
 Tel. +41 61 - 695 55 55
 Fax +41 61 - 695 55 10
 www.sauter-controls.com
 info@sauter-controls.com